

SL1 SWITCH

WHAT IS THE SL1 SWITCH?

- 113CMX20CMX2CM - 45X7.8X0.8"
- 170W MAX CONSUMPTION
- 3.4 KG - 7.5 LBS
- 3000°K TO 5600°K
- 24VDC
- FLICKER FREE AT ANY FRAME RATE
-  **RoHS CE**

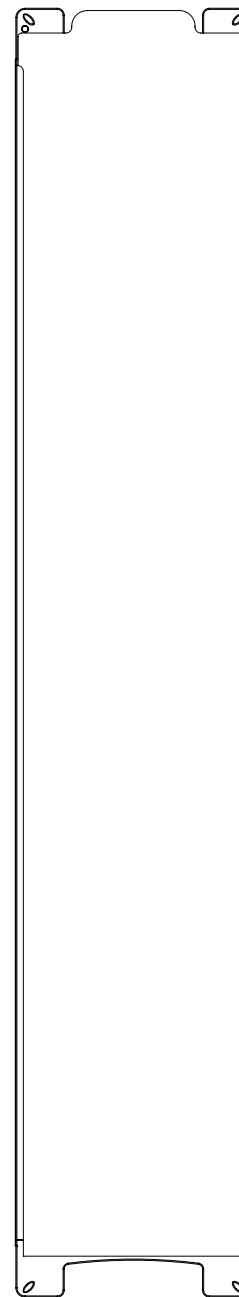

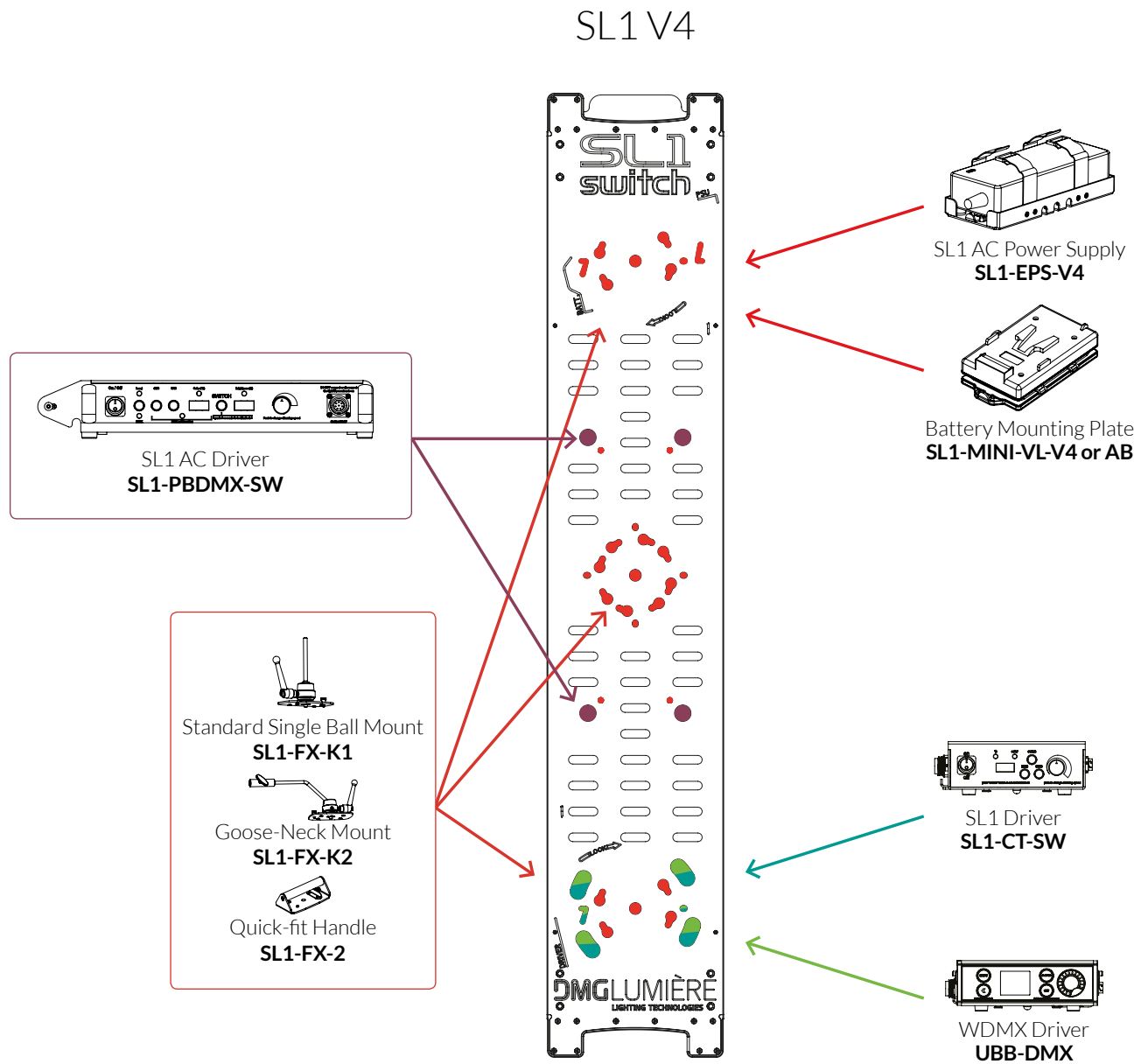

1. PBDMX

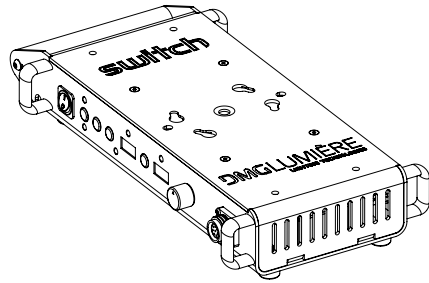

SL1 AC Driver - Wired DMX - AC Power supply inside

3. UBB DMX

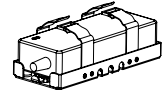
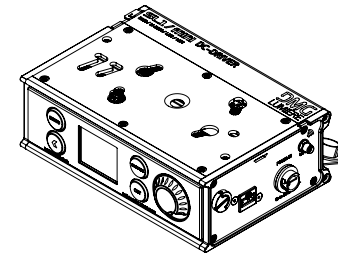

AND/OR

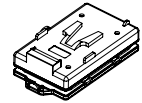

SL1 DC/DC Driver with DMX/WDMX/Wifi - EPS or VL/AB plate required to power

2. SL1 CT

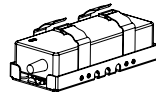
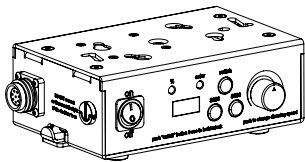

AND/OR

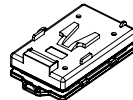

SL1 DC/DC Driver (Basic, no DMX) - EPS or VL/AB plate required to power

MOUNTING THE SL1:

- Attaching the mount:
With the SL1, you have either purchased a K1, K2 or handle mount.

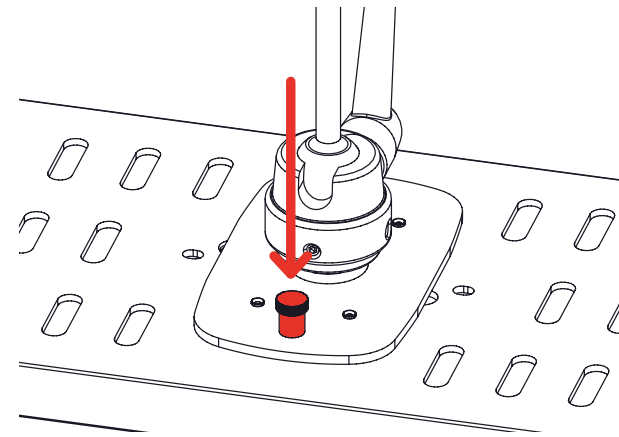
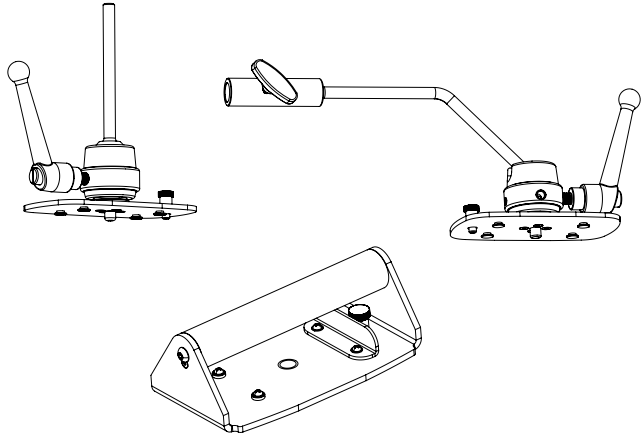

SAFETY WARNING: Make sure the mount is properly fixed and the pin is all the way down before setting the SL1 on a stand or overhead.

- Place the Mount at the center of the SL1 and apply a quarter turn until the spring loaded pin drops in it's lodging.

- Secure the SL1 with the safety cables:

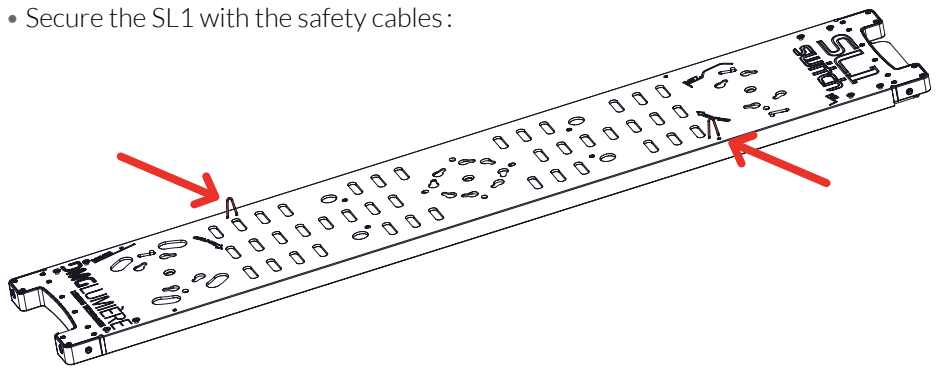
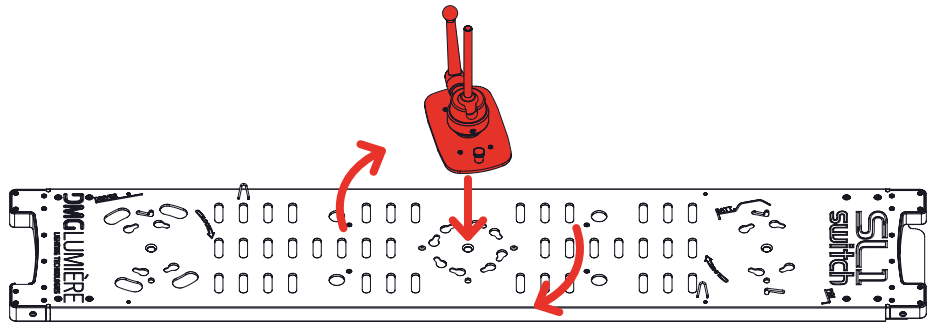

MOUNTING THE SL1 (CONTINUED):

- If you have purchased the SL1 with the Powerbox, you can attach the Powerbox at the back of the light before attaching the mount:
 1. Place the SL1 on a flat surface.
 2. Place the Powerbox on the back of the light, making sure the 4 feet are in their lodging.
 3. With an Allen Key n°4, screw the 4 spring loaded screw of the Powerbox to the SL1. Make sure the 4 screws are properly attached.

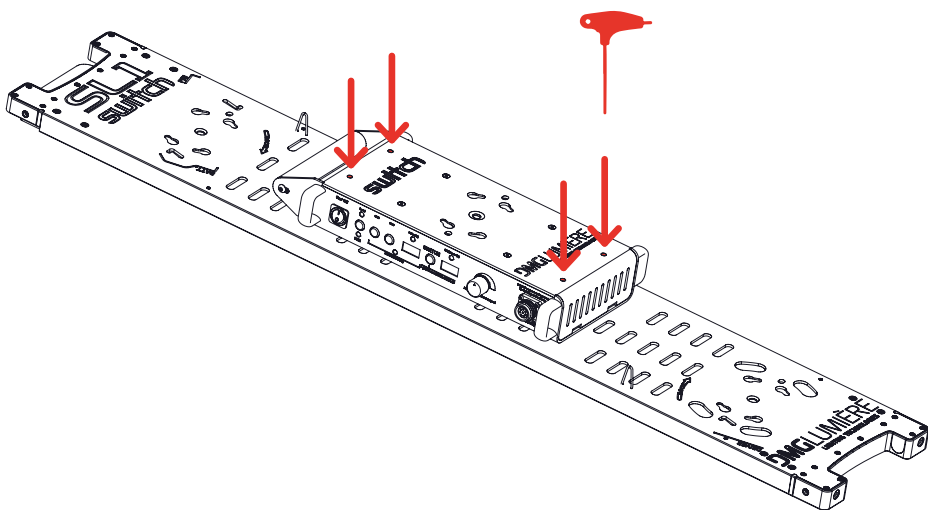

- Once the Powerbox is attached you can mount any of the mounts to the Powerbox like you would on the head.

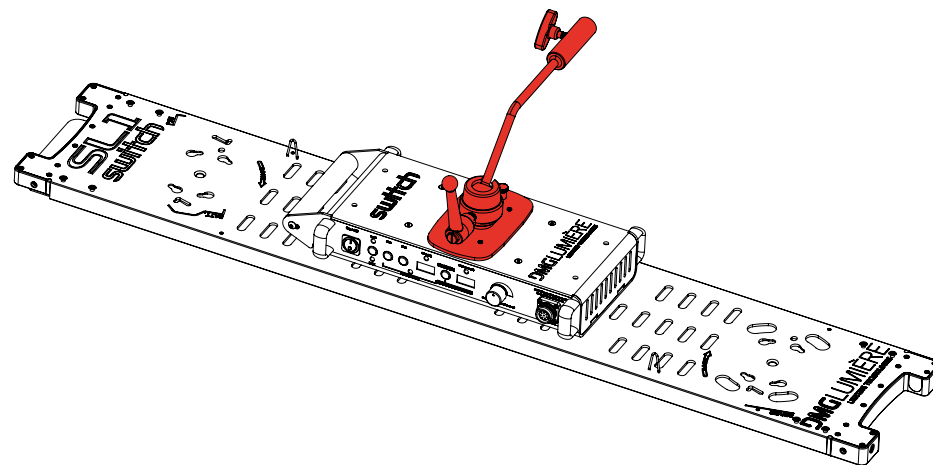

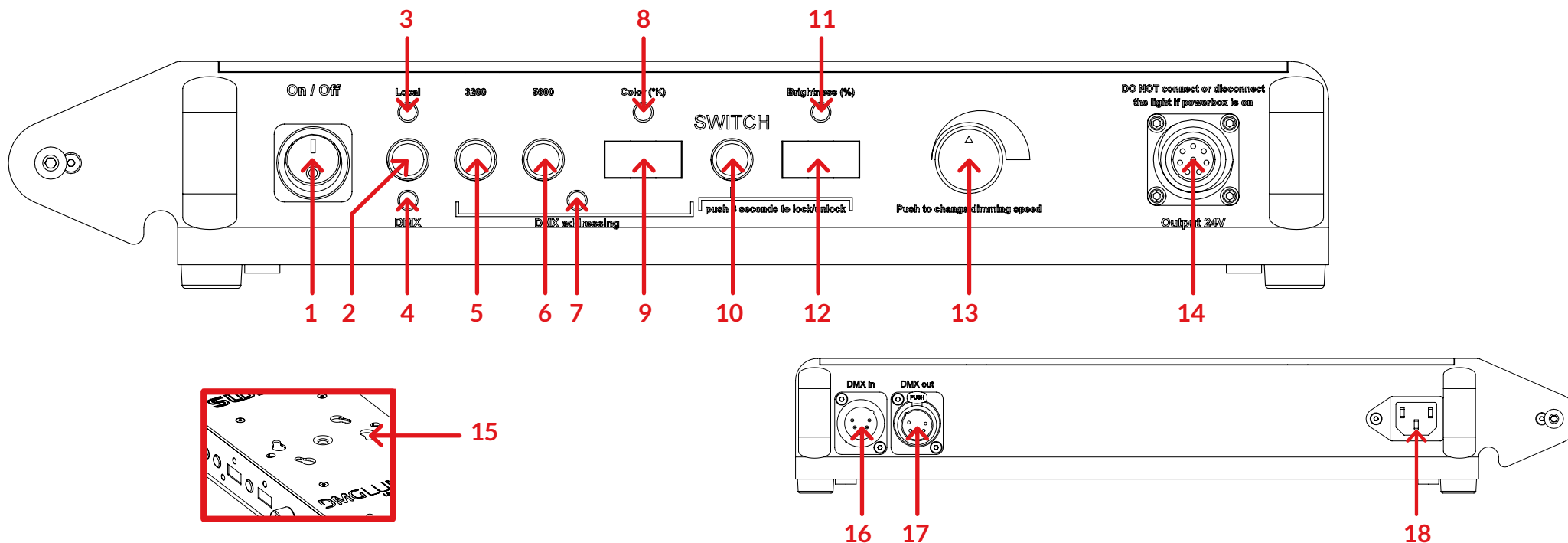

1. On/Off

2. DMX SWITCH

- Switch between local and DMX control

3. Local Indicator

- If ON, the light is in local control mode

4. DMX Indicator

- If ON, the light is in DMX control mode

5. 3200/DMX Addressing

- In LOCAL mode, switches the CCT to 3200°K

- In DMX mode, allows input of DMX channel

6. 5600/DMX Addressing

- In LOCAL mode, switches the CCT to 5600°K
- In DMX mode, increments the DMX digit

7. DMX Signal

- Red : no DMX input
- Blinking Green: DMX signal received

8. COLOR Indicator

- If ON, the dimmer controls the CCT

9. CCT Display

10. SWITCH Button

- Switch the function of the dimmer, from CCT control to INTENSITY control

11. Intensity Indicator

- If ON, the dimmer controls the intensity

12. Intensity Display

13. Dimmer

- Changes CCT or intensity

14. Power Out

- Power out to the SL1 Head light

15. Female Plate

- Female plate for K1, K2 or Handle Mount

16. DMX IN - XLR5

17. DMX OUT - XLR5

18. Power IN - IEC

CONTROLLING THE SL1:

SAFETY WARNING: Make sure power is off before connecting or disconnecting the SL1 to the controls.

- If you have attached the controls at the back of the light, you can connect the cable-out directly to the controls. If you need to distance the SL1 from its controls, you can add the extension cable.

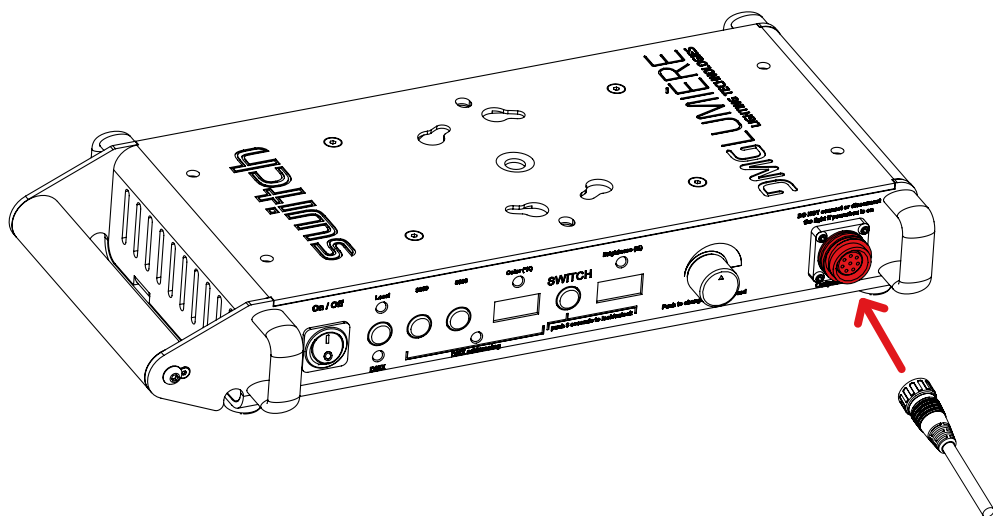

- Once the SL1 is connected to the controls, you can connect the control to the power source (AC for the POWERBOX, to the external power supply or a battery for the DC/DC drivers).

- Turn on the controls with the ON/OFF button.

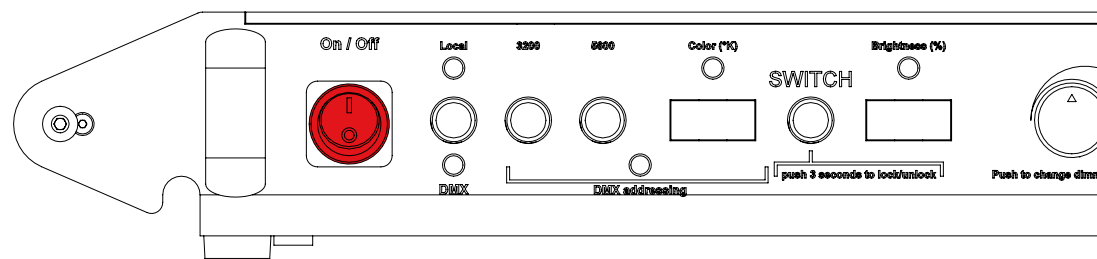

In local mode:

- To control the brightness of the light, make sure to press the SWITCH button until the “Brightness” indicator is on. You can now control the brightness with the dimmer button.
- You can switch the increment from 1% to 0.1% by pressing the dimmer button.
- To switch from brightness to color temperature, press the SWITCH button once more until the “Color” indicator is on. You can now control the color of the SL1 with the dimmer button, from 3000°K to 5600°K.
- You can also press the 3200°K or 5600°K button to setup the light directly at those color temperatures.

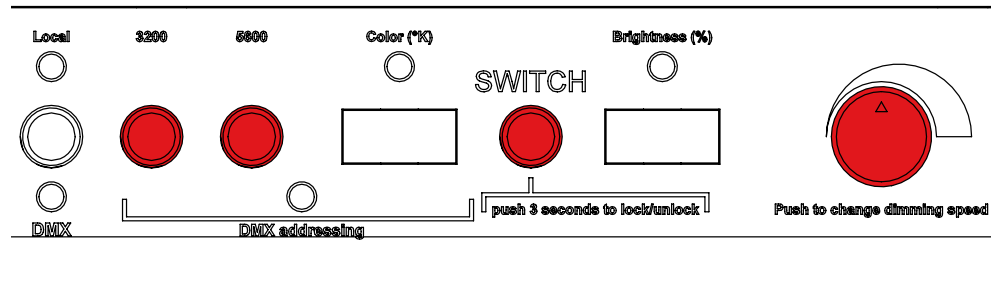

CONTROLLING THE SL1 (CONTINUED):

Setting up the DMX MODE:

The SL1 one takes 2 DMX channels, channel one is the brightness, channel 2 the color temperature.

- First, plug in your XLR 5 in the DMX IN connector

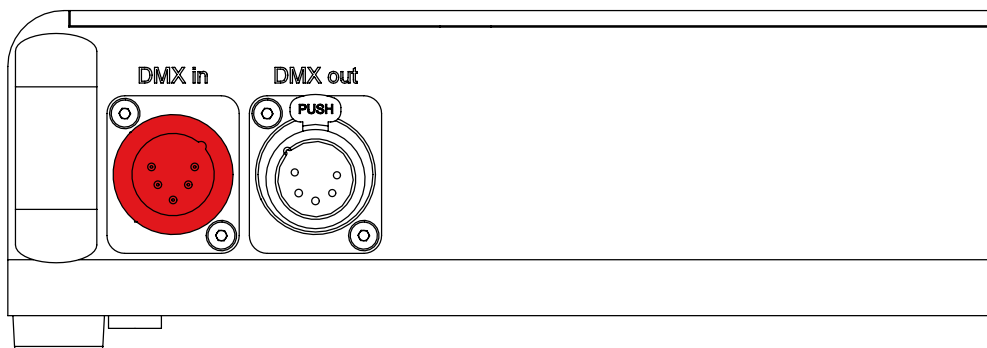

- Then, to control the SL1 in DMX, you need to switch from LOCAL to DMX mode. Do this by pressing the button between LOCAL and DMX. The DMX indicator will turn on when in DMX mode.

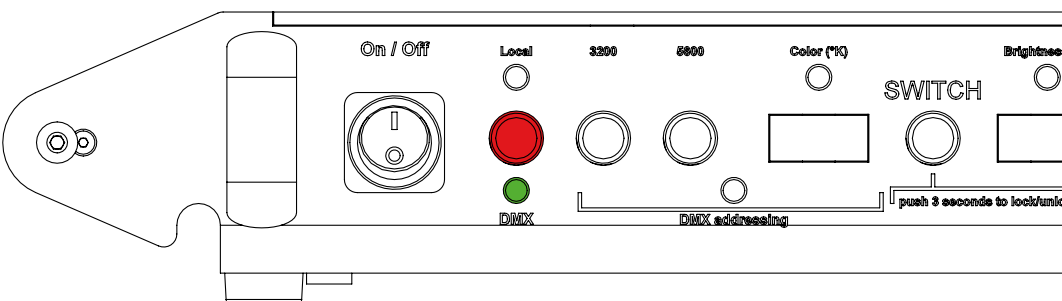

- To setup the DMX address, press the first DMX button (also the 3200°K button). The first digit can be set by pushing the second DMX button (also the 5600°K button).
- Press the 3200°K button again to change of digit. Repeat until all of your digits are set.

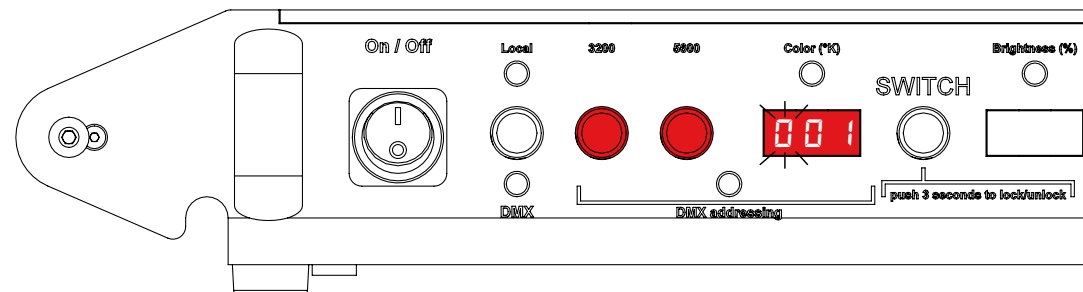

NB: On the SL1 you set up only the first channel. For example, if you set up the DMX address to 005, channel 005 is the brightness, channel 006 the color temperature.

- Once the address is set, the DMX indicator will blink if a DMX signal is received. Otherwise, please check your DMX signal.

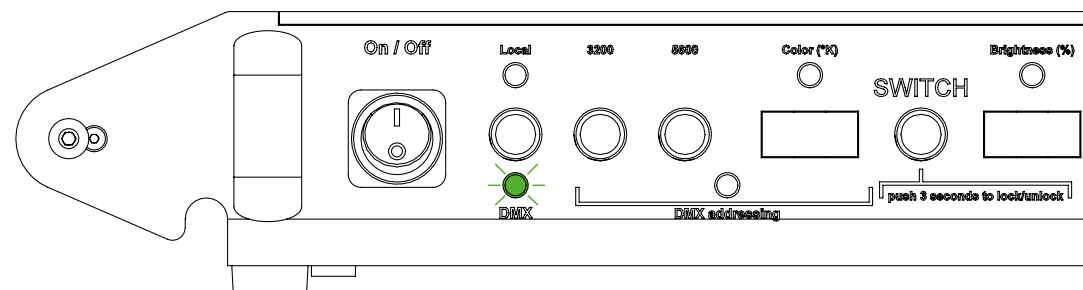

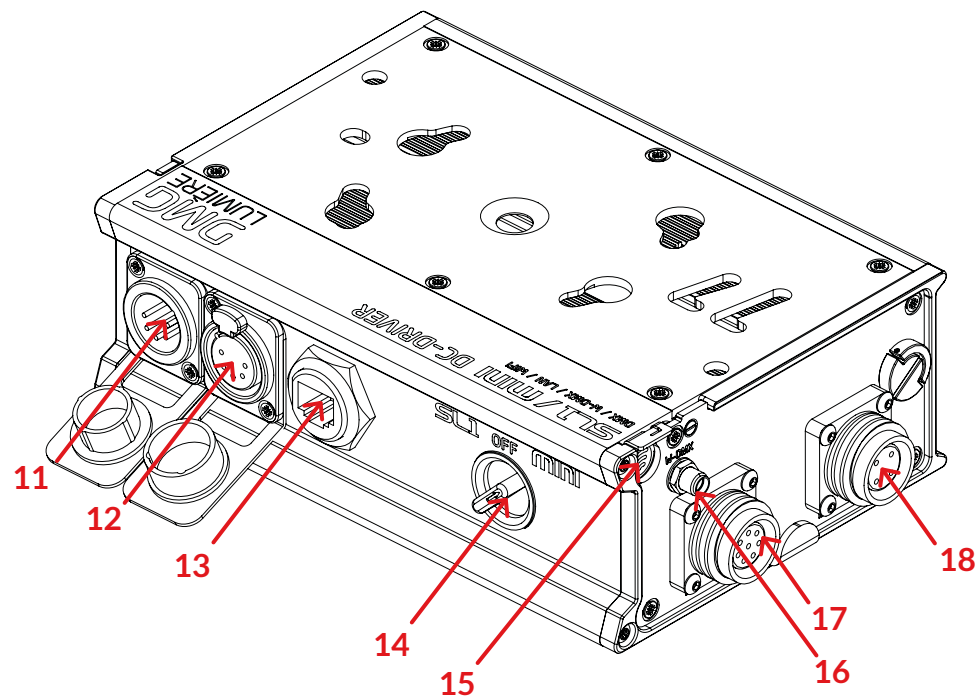
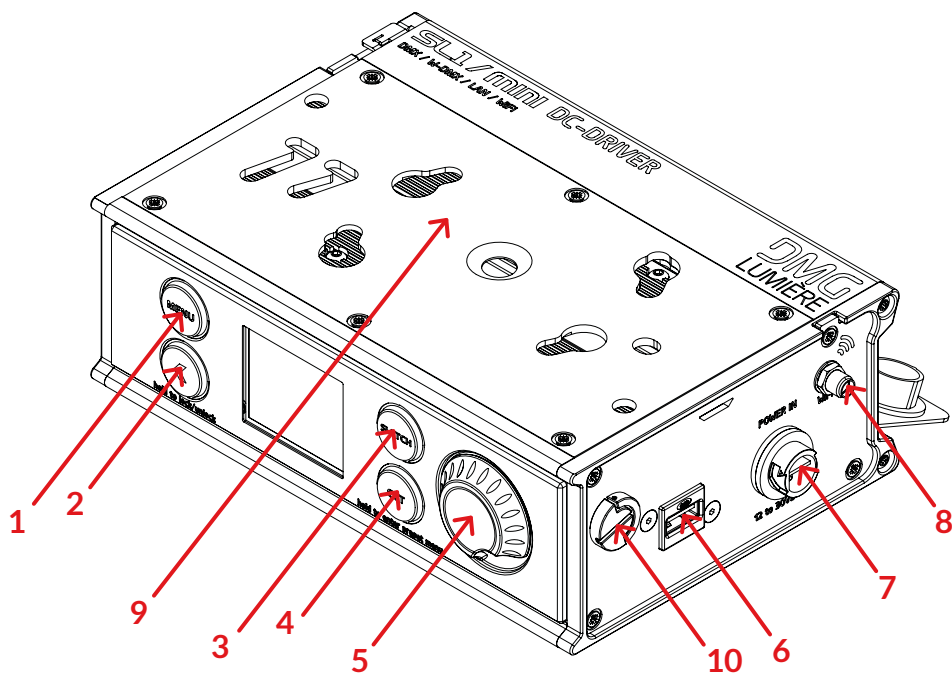

1. Menu

- Go to the general menu

2. Back

- Step back in menu
- Lock/unlock UBB when pressed for 2secs.

3. SWITCH

- Change between CCT and intensity control

4. CCT

- Quickly change from 3200°k to 5600°K
- Enter the preset menu to store or recall values

5. Dimmer button

- Press to change intensity or CCT
- Select fine or coarse dimming when pressed
- Navigate through the menu and push to validate

6. USB plug

- Upgrade the UBB's firmware

7. 12~30VDC input

8. Connector for Wifi antenna

9. Mounting plate for EPS and Battery mounts

10. Attachment for shoulder strap

11. DMX IN

12. DMX OUT

13. LAN IN

14. ON/OFF

- Turns SL1 or MINI SWITCH ON

15. Door for antennas storage

16. Connector for Wireless DMX antenna

17. 8 pins connector for SL1 SWITCH

18. 4 pins connector for Mini SWITCH

1. Connect the UBB to a power source (DMG EPS, DMG Battery mount or any 12 to 30VDC power supply)
2. Connect the Mini SWITCH or SL1 SWITCH to the UBB
3. Turn on the UBB by selecting which light you are powering (SL1 or Mini)

Four modes are available:

- LOCAL MODE
- DMX MODE
- Wireless DMX MODE
- CUSTOM MODE

LOCAL MODE:

Control the UBB locally with the dimmer button.

- Press the SWITCH button to change between CCT and intensity control
- Press CCT button for a quick change between 3200°K and 5600°K
- Press the dimmer button to select coarse or fine intensity tuning

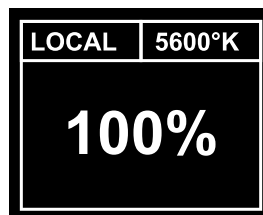

DMX MODE:

Control the UBB remotely by cable with the DMX protocol.

- Press the dimmer button to enter the DMX start number of the UBB

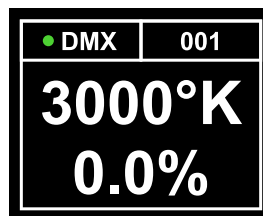

WIRELESS DMX MODE:

Control the UBB remotely with the Wireless DMX protocol.

- Make sure the Wireless DMX antenna should be installed
- Press the dimmer button to enter the DMX start number of the UBB
- Validate by pressing go

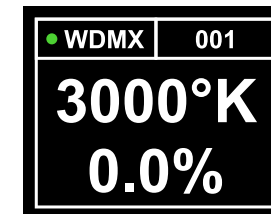

Wireless DMX dot is red when no signal is received, green when the UBB is connected to a Wireless DMX emitter.

To synchronize with a new emitter, go back to general menu and enter Wireless DMX mode again.

CUSTOM MODE:

In custom mode the UBB acts as a translator between different protocols. It still controls the SL1 SWITCH or Mini SWITCH connected to it.

- Make sure the Wireless DMX antenna should be installed if using Wireless DMX.
- Make sure the Wi-Fi antenna should be installed if using Wi-Fi.
- Press the dimmer button to select data input, data output and DMX address.
- Validate by selecting «Go».

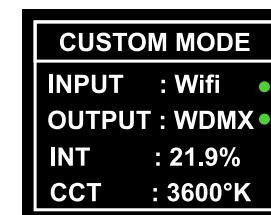

If Wi-Fi input is selected, the UBB creates a Wi-Fi networks with the following specifications:

SSID: UBB serial number
Password: dmglumiere

These informations can be find in the “info” section of the UBB menu.

Wireless DMX dot is red when no signal is received, green when the UBB is connected to a Wireless DMX emitter.

- To synchronize with a new emitter, go back to general menu and enter Wireless DMX mode again.

CUSTOM MODE (FOLLOWING):

(...)

Wi-Fi dot is red when no signal is received, green when the UBB is connected to a Wi-Fi device with an Art-Net app enabled.

UPGRADING THE UBB:

- Download the firmware from the DMG Lumière website:
dmglumiere.com/upgrade
- Copy the file to a USB stick
- Insert the USB key in the UBB.
If a correct file is found on the USB stick, the UBB will prompt an upgrade menu.
- Select YES to upgrade
- Wait for upgrade to finish. The UBB will turn off and on automatically to activate the upgrade.

INFO:

Displays the firmware version, the Network name and password for the Wi-Fi mode.

USER MANUAL - UBB USAGE EXAMPLE

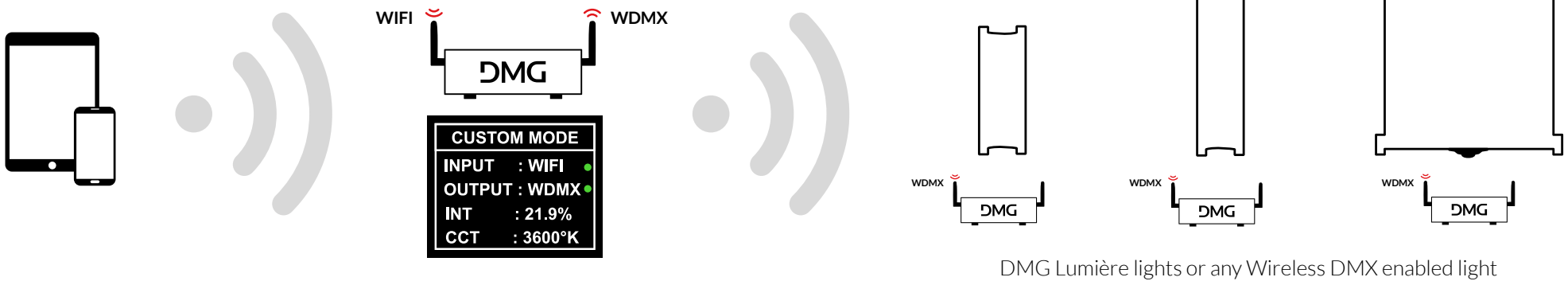
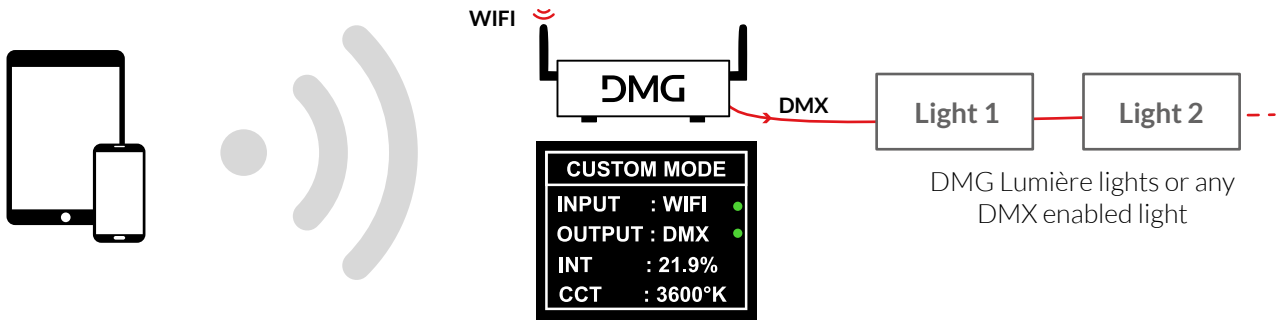
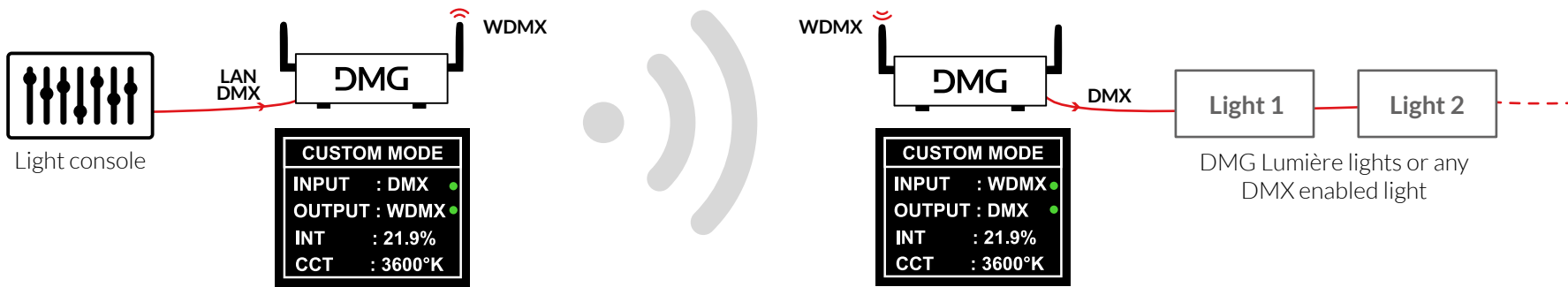

Our wireless DMX is compatible with any  lumenradio powered devices.

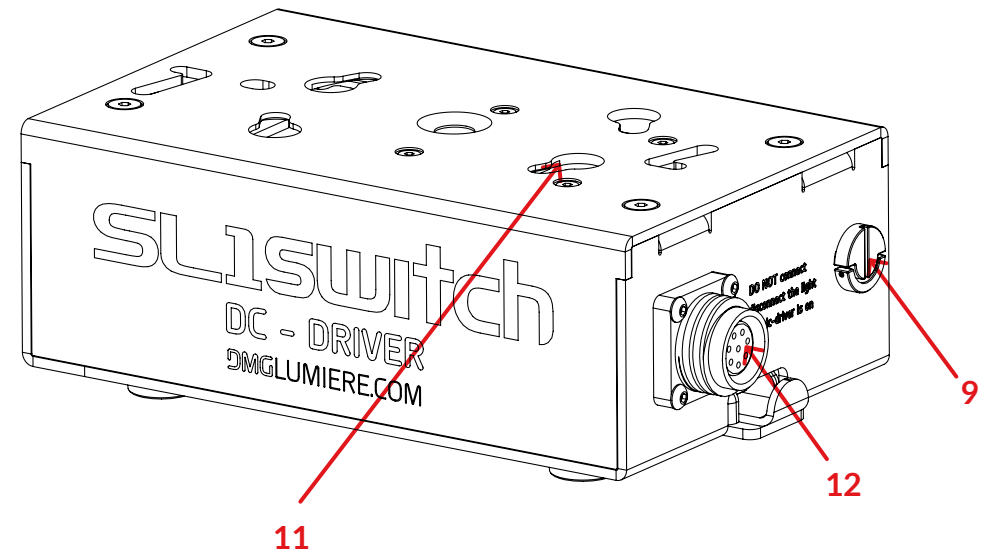
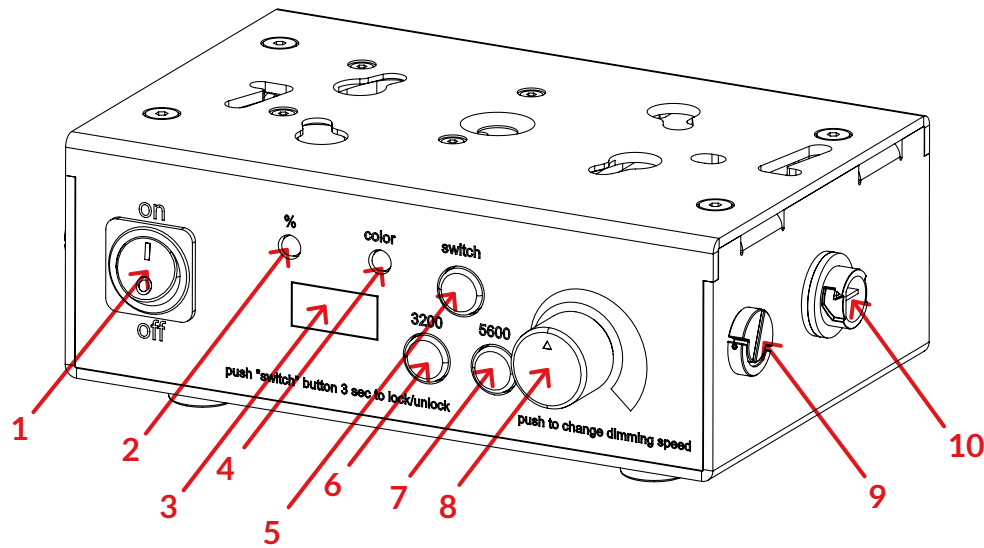

CT GUIDELINES

1. On/Off

2. Intensity Indicator

- If ON, the dimmer controls the intensity

3. Intensity Display

4. Color Indicator

- If ON, the dimmer controls the CCT

5. SWITCH Button

- Switch the function of the dimmer, from CCT control to INTENSITY control

6. 3200°K Addressing

- Switches the CCT to 3200°K

7. 5600°K Addressing

- Switches the CCT to 5600°K

8. Dimmer

- Changes CCT or intensity

9. Attachments for shoulder strap

10. 12~35 VDC input

11. Mounting plate for EPS and Battery mounts

12. Power Out

- Power out to the SL1 Head light

- 1.** Connect the CT to a power source (DMG EPS, DMG Battery mount or any 12 to 35VDC power supply)
- 2.** Connect the SL1 SWITCH to the CT
- 3.** Turn on the CT

SAFETY AND PRECAUTIONS:

General precautions

- DMG Lumière products are made to be used by trained professionals only. DMG Lumière products are not for household use.

Risk of falling

- If the SL1 SWITCH, the MINI SWITCH or the MAXI SWITCH are not secured with their two security cables on the lights, there is a risk of falling and death.
- Make sure the slings or chains chosen to secure the light complies with standards in the country you are in.

Risk of electric shock and fire

- High voltage when using with the powerbox and External power supply !
- Use only the power supplies sold by DMG Lumière to power the lights.
- When inputting 220V or 110V AC current, make sure the POWERBOX is connected to the ground before using.
- Do not open the product. There are no user serviceable parts inside.

Overheating

- Do not operate the product if the ambient temperature exceeds 45° C.
- Intensive use can cause the surface to become hot .
- Let the product cool down completely before you handle it.
- Do not cover the air vents !

Intense light

- Do not look at the light directly

Warnings

- Stage and Studio Use Only
- Dry Location Only
- Hazardous Voltage
- Risk of Electrical Shock
- Disconnect Power Before Servicing
- Not For Residential Use

Approvals

EU Safety:

- EN 55015:2013
- EN 61547:2009
- EN 61000-3-2:2014
- EN 61000-3-3:2013
- EN 61000-4-2:2009
- EN 61000-4-3:2006+A1:2008+A2:2010
- EN 61000-4-4:2012
- EN 61000-4-5:2006
- EN 61000-4-6:2009
- EN 61000-4-8:2010
- EN 61000-4-11:2004
- EN 62471

FCC:

- 47 CFR of part 15

CSA and UL:

- CSA C22.2 No. 250.4-14
- CAN/CSA C22.2 No. 250.13-14
- UL Standard No. 153
- UL Standard No. 8750

ROHS:

- EPA3050B:1996
- EN1122B:2011
- EPA3052:1996
- EPA7196A:1992
- APE3540C:1996
- EPA8270D:2007